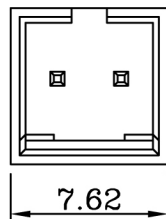
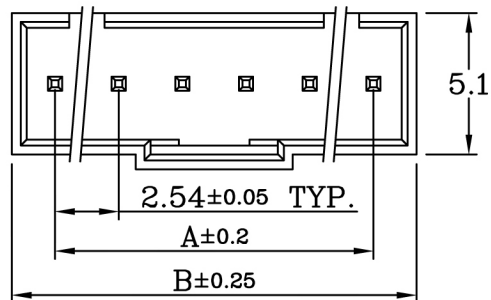
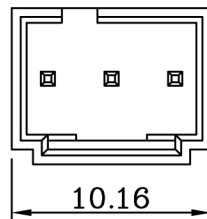
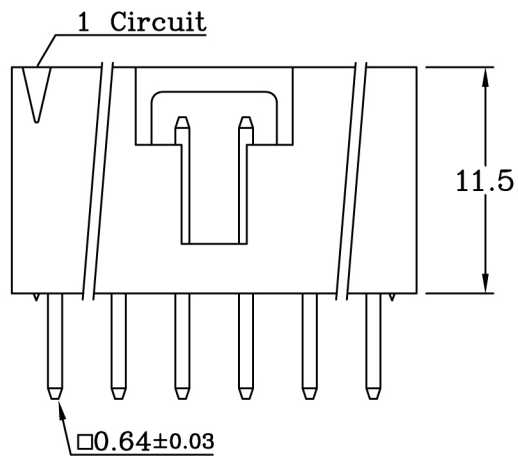
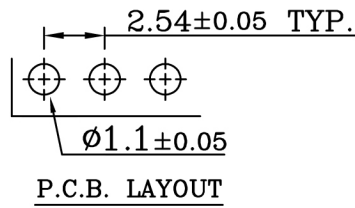
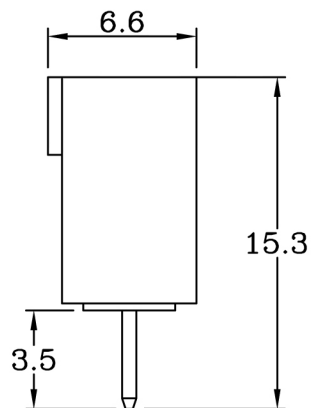

A**B****C****D****E**2 Circuit3 Circuit**Specifications:**● **Material:**

Base: Polyester 94V-0, PBT+30% glass-filled
 Contact: Brass, Gold-Plated

● **Voltage Rating:** 250V● **Current Rating:** 3A● **Withstand Voltage:** 1000V AC/Minute● **Insulation Resistance:** 1000MΩ min.● **Temperature Range:** -25°C~+85°C

● **Contact Resistance:** Initial value/10mΩ max.
 After environmental testing/20mΩ max.

1 CircuitP.C.B. LAYOUT**Dimensional & Ordering Information:**

Circuits	Part No	Dimensions mm	
		A	B
2	CPU-02S	2.54	7.62
3	CPU-03S	5.08	10.16
4	CPU-04S	7.62	12.70
5	CPU-05S	10.16	15.24
6	CPU-06S	12.70	17.78
7	CPU-07S	15.24	20.32
8	CPU-08S	17.78	22.86
9	CPU-09S	20.32	25.40
10	CPU-10S	22.86	27.94
11	CPU-11S	25.40	30.48
12	CPU-12S	27.94	33.02

所有材料為
 "環保材料"
 2006.11.14
 RoHS

DESCRIPTION(內容):
 2.54mm (.100") Pitch
 Wire-to-Board Header

PART NO:
 (料號) CPU-XXS
 DWG NO(圖號): 2545-ST

DRAWN(製圖):
 jamie
 CHECKED(確認):
 MANDY
 APPROVAL(核准):
 JOHNNY

GENERAL TOLERANCE:
 (公差)
 .000 : ±0.08
 .00 : ±0.13
 .0 : ±0.25

SCALE(比例):
 FREE



REV:
 R2
 UNIT:
 mm
 SIZE:
 A4
 SHEET:
 1/1

REV
 R0
 R1
 R2
 R3

DESCRIPTION

環保料

2007年圖面版本更新

變更電鍍成份

DATE

2007.08.11

2007.10.09

2008.05.08

A**B****C****D****E**

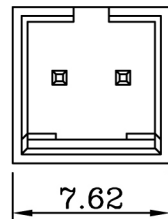
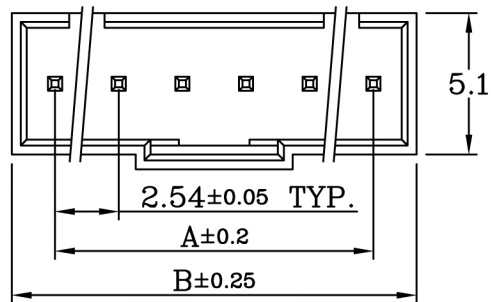

2 Circuit

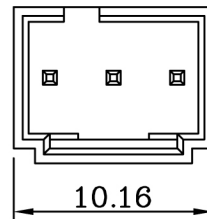

3 Circuit

Specifications:

- Material:
Base: Polyester 94V-0, PBT+30% glass-filled
Contact: Brass, Gold-Plated
- Voltage Rating: 250V
- Current Rating: 3A
- Withstand Voltage: 1000V AC/Minute
- Insulation Resistance: 1000MΩ min.
- Temperature Range: -25°C~+85°C
- Contact Resistance: Initial value/10mΩ max.
After environmental testing/20mΩ max.

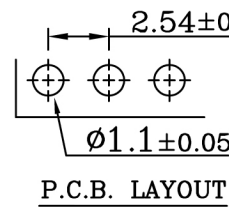
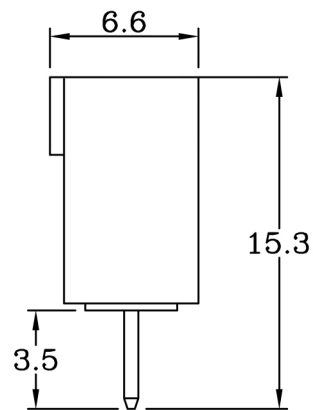
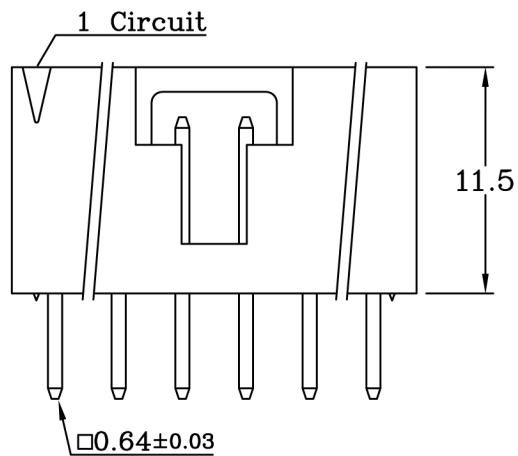

P.C.B. LAYOUT

Dimensional & Ordering Information:

Circuits	Part No	Dimensions mm	
		A	B
13	CPU-13S	30.48	35.56
14	CPU-14S	33.02	38.10
15	CPU-15S	35.56	40.64
16	CPU-16S	38.10	43.18
17	CPU-17S	40.64	45.72
18	CPU-18S	43.18	48.26

NOTE: MOQ 200KPIN

所有材料為
"環保材料"
2006.11.14
RoHS

DESCRIPTION(內容):	DRAWN(製圖): JAMIE	GENERAL TOLERANCE:(公差)	REV:	REV	DESCRIPTION	DATE
			2.54mm (.100") Pitch Wire-to-Board Header	CHECKED(確認): MANDY		
PART NO: (料號) CPU-XXS	APPROVAL(核准): JOHNNY	SCALE(比例): FREE	UNIT: mm	R1	變更電鍍成份	2008.05.08
DWG NO(圖號): 2545-ST			SIZE: A4	R2		
			SHEET: 1/1	R3		